

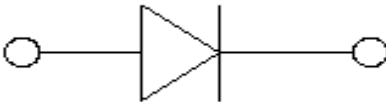

Schottky Rectifier



Features

- V_R 20V/30V/40V
- I_{FAV} 0.5A
- For Surface Voltage and Extremely Low Thermal Resistance
- Moisture Sensitivity Level 1

Mechanical Data

- **Package:** SOD123
- **Terminals:** Tin plated leads, solderable per J-STD-002 and JESD22-B102
- **Polarity:** Cathode line denotes the cathode end
- **Marking:**

MBR0520	R2
MBR0530	R3
MBR0540	R4

■Maximum Ratings (Ta=25°C Unless otherwise specified)

PARAMETER	SYMBOL	UNIT	Conditions	VALUE	
Maximum Recurrent Peak Reverse Voltage	V_{RRM}	V		MBR0520	20
				MBR0530	30
				MBR0540	40
DC Blocking Voltage	V_R	V	$I_R=0.2mA$	MBR0520	20
				MBR0530	30
				MBR0540	40
Peak forward surge current	I_{FSM}	A	8.3ms, half sine	5.5	
Repetitive Peak Forward Current	I_{FRM}	A	$t_p=1ms, \delta=0.25$	2.5	
Average forward current	I_{FAV}	A		0.5	
Power dissipation	P_{tot}	mW		410	
Thermal Resistance from junction to ambient(Note)	$R_{\theta JA}$	°C/W		244	
Maximum junction temperature	T_j	°C		-55 to +125	
Storage temperature range	T_{stg}	°C		-55 to +125	

Note: Device mounted on PCB

■Ordering Information (Example)

PREFERRED P/N	PACKING CODE	UNIT WEIGHT(g)	MINIMUM PACKAGE(pcs)	INNER BOX QUANTITY(pcs)	OUTER CARTON QUANTITY(pcs)	DELIVERY MODE
MBR0520	F2	Approximate 0.011	3000	30000	120000	7" reel
MBR0530	F2	Approximate 0.011	3000	30000	120000	7" reel
MBR0540	F2	Approximate 0.011	3000	30000	120000	7" reel



MBR0520 THRU MBR0540

■ Electrical Characteristics (T_a=25°C Unless otherwise specified)

PARAMETER	Symbol	UNIT	Conditions	Value	
Breakdown Voltage	V _R	V	I _R =0.2mA	MBR0520	20
				MBR0530	30
				MBR0540	40
Forward Voltage	V _F	V	I _F =0.5A	MBR0520	0.45
				MBR0530	0.55
				MBR0540	0.55
Reverse Leakage Current (MAX)	I _R	mA	V _R =20V	MBR0520	0.2
			V _R =30V	MBR0530	
			V _R =40V	MBR0540	
Typical Junction Capacitance	C _J	pF	V _R =4V, f=1MHz	40	

■ Characteristics (Typical)

MBR0520

Fig 1: P_D-T_a Curve

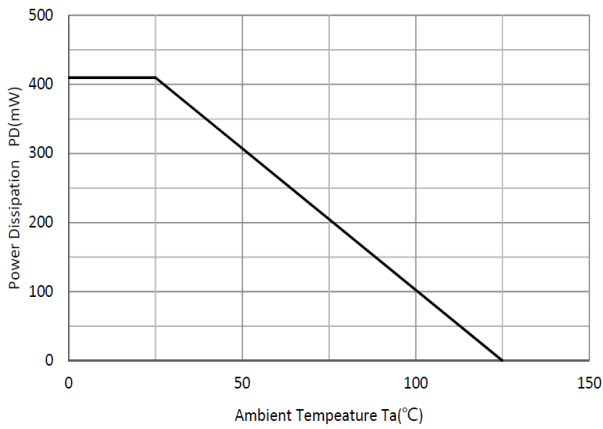

Fig 2: Capacitance Capability

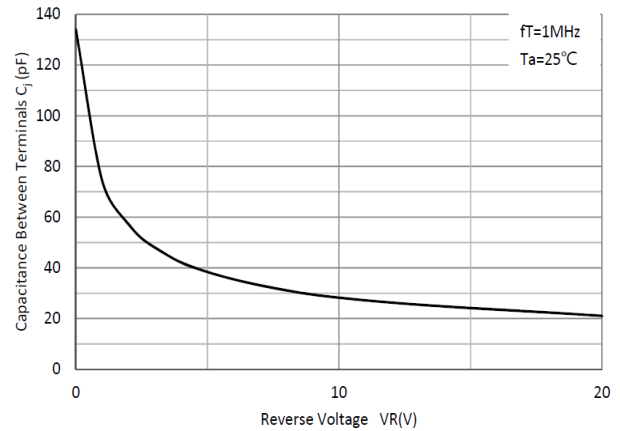

Fig 3: Typical Forward Characteristics

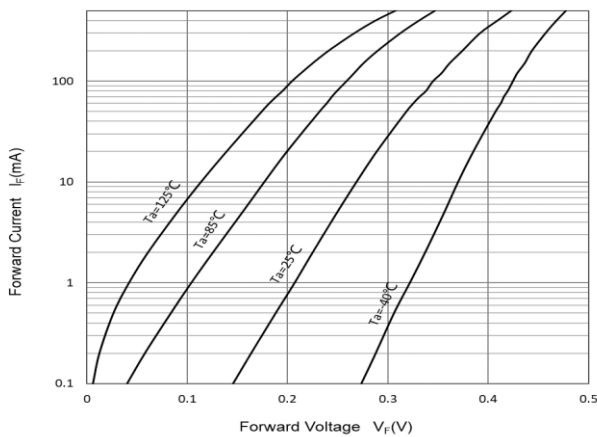
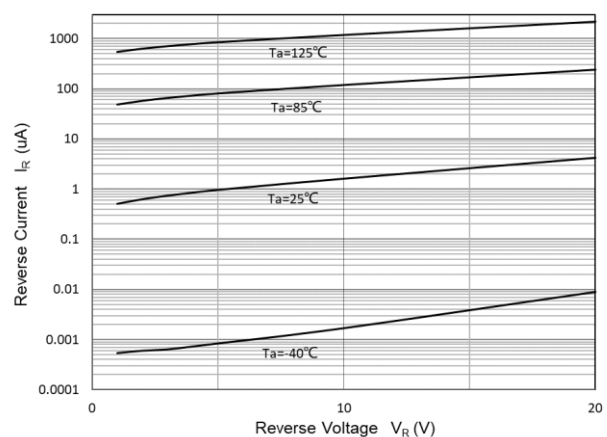

Fig 4: Typical Reverse Characteristics





MBR0520 THRU MBR0540

MBR0530

Fig 1: Typical Forward Characteristics

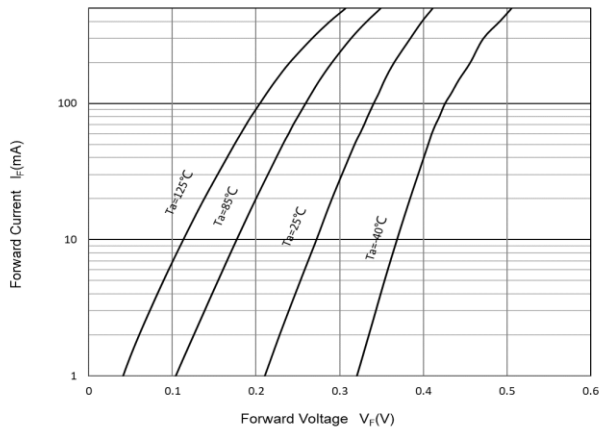

Fig 2: Typical Reverse Characteristics

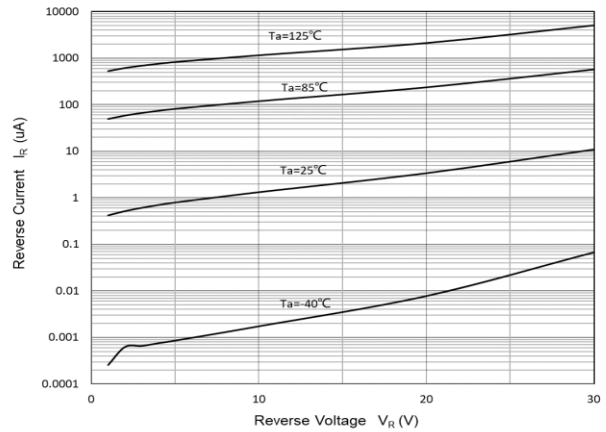
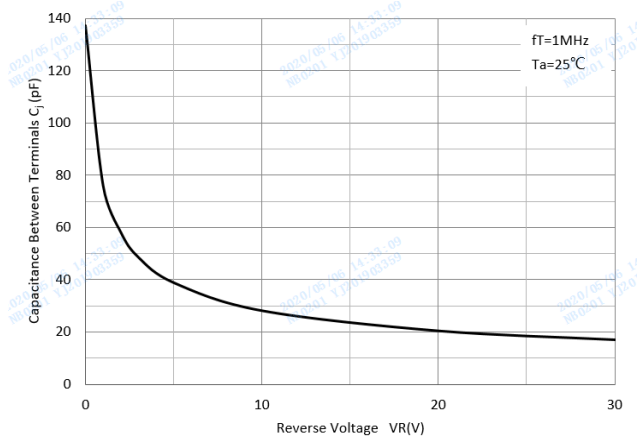

Fig 3: Capacitance Capability





MBR0520 THRU MBR0540

MBR0540

Fig 1: Typical Forward Characteristics

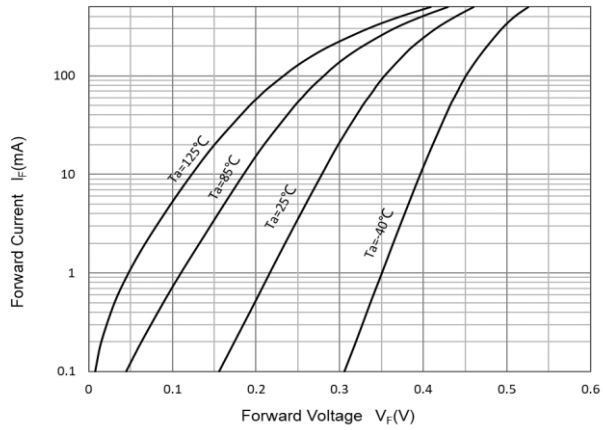

Fig 2: Typical Reverse Characteristics

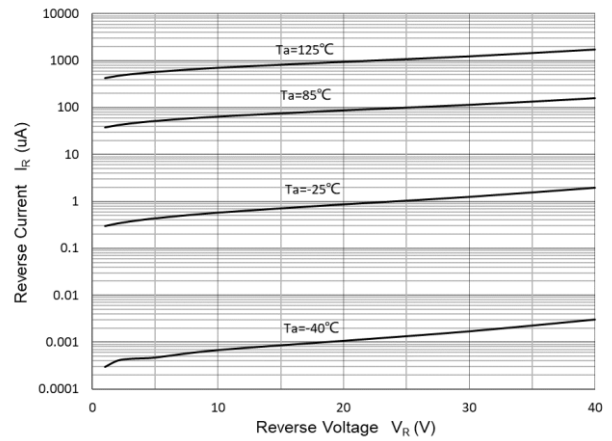
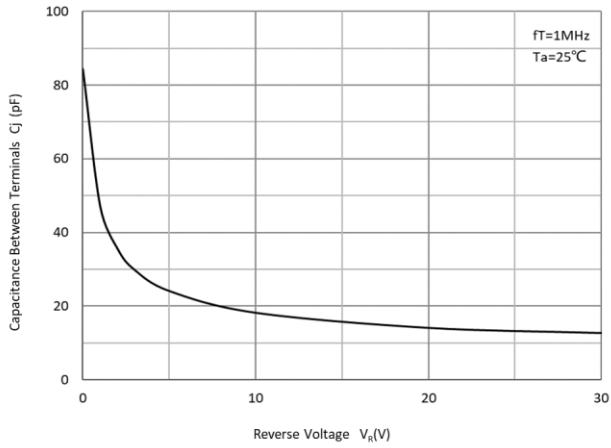

Fig 3: Capacitance Capability





MBR0520 THRU MBR0540

■ Outline Dimensions

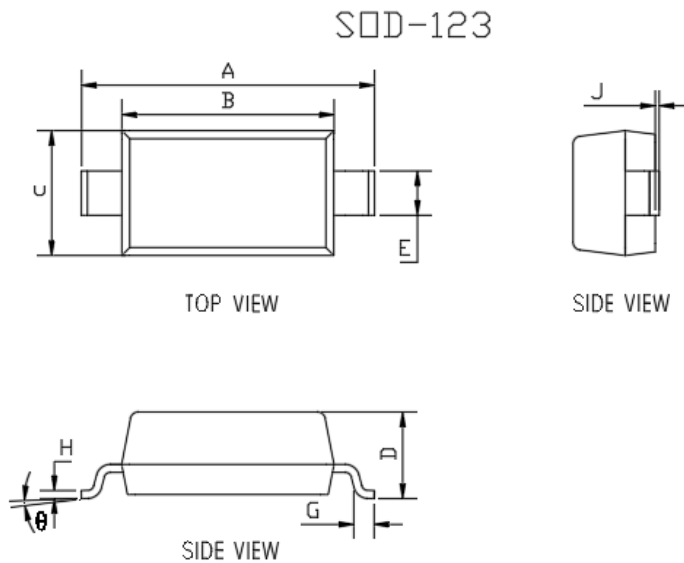

DIMENSIONS				
DIM	INCHES		MM	
	MIN	MAX	MIN	MAX
A	0.140	0.152	3.550	3.850
B	0.100	0.112	2.550	2.850
C	0.055	0.071	1.400	1.800
D	0.037	0.053	0.950	1.350
E	0.020	0.028	0.510	0.710
G	0.006	0.018	0.150	0.450
H	0.003	0.010	0.080	0.250
J	0.000	0.006	0.000	0.150
θ	0	8°	0	8°

■ Soldering Footprint

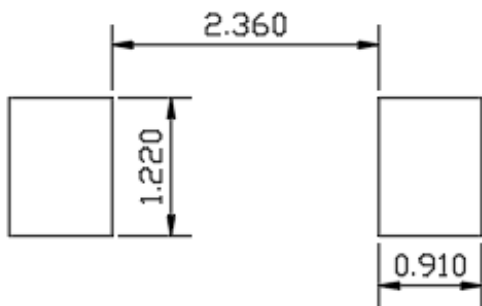

UNIT : mm

SUGGESTED SOLDER PAD LAYOUT

Note:

- All dimensions are in millimeters (mm) unless otherwise specified.
[所有尺寸均以毫米为单位, 除非另有说明]
- General tolerances: $\pm 0.10\text{mm}$ unless otherwise specified.
[通用公差为 $\pm 0.10\text{mm}$, 除非另有说明]
- Dimensions and tolerances per ASME Y14.5M-2018.
[尺寸和公差遵循 ASME Y14.5M-2018 标准]
- All dimensions shown are exclusive of burrs and gate residues.
Burrs and gate vestiges shall not exceed 0.15 mm in maximum.
[所有尺寸均不包括毛刺和浇口残留。毛刺与浇口残留的尺寸最大不得超过 0.15mm]
- Dimension b does not include dambar protrusion of max 0.100 mm per side.
[尺寸b不包括单边最大0.100 MM的中筋凸出部分]
- Dimensions B and C are the overall extreme outer dimensions of the mold compound. These dimensions exclude mold flash, lead flash, protrusions and burrs but include the maximum allowable mold mismatch.
[B和C是塑封体的外部极限尺寸, 不包括包封溢料、内引线溢料、凸出部分以及胶体毛刺, 但是包含了包封错位的最大尺寸]
- Formed leads shall be planar with respect to one another within a maximum of 0.076 mm relative to the seating plane.
[成型的管脚应为同一平面, 共面性最大为0.1mm]



MBR0520 THRU MBR0540

Disclaimer

The information presented in this document is for reference only. Yangzhou Yangjie Electronic Technology Co., Ltd. reserves the right to make changes without notice for the specification of the products displayed herein to improve reliability, function or design or otherwise.

The product listed herein is designed to be used with ordinary electronic equipment or devices, and not designed to be used with equipment or devices which require high level of reliability and the malfunction of which would directly endanger human life (such as medical instruments, transportation equipment, aerospace machinery, nuclear-reactor controllers, fuel controllers and other safety devices), Yangjie or anyone on its behalf, assumes no responsibility or liability for any damages resulting from such improper use of sale.

This publication supersedes & replaces all information previously supplied. For additional information, please visit our website [http:// www.21yangjie.com](http://www.21yangjie.com) , or consult your nearest Yangjie's sales office for further assistance.