

## N-Channel Enhancement Mode Field Effect Transistor

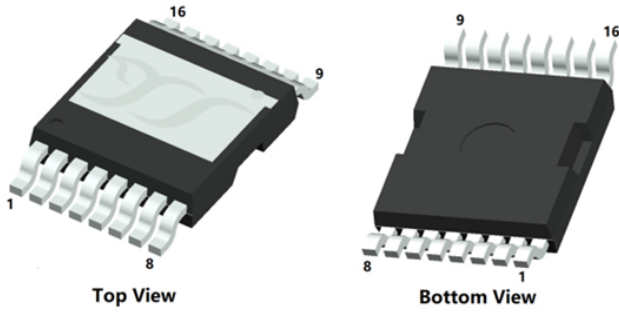

TOLT

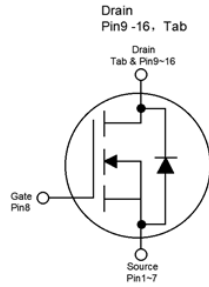

### Product Summary

• $V_{DS}$	80V
• $I_D$	453A
• $R_{DS(ON)}$ ( at $V_{GS}=10V$ )	< 1.13m $\Omega$
• 100% EAS Tested	
• 100% $\nabla V_{DS}$ Tested	
• ESD Level(HBM)	H3A

### General Description

- Excellent package for heat dissipation
- High density cell design for low  $R_{DS(ON)}$
- Moisture Sensitivity Level 1
- Epoxy Meets UL 94 V-0 Flammability Rating
- Halogen Free
- Part no. with suffix "Q" means AEC-Q101 qualified

### Applications

- BLDC Motor driver
- Load Switch
- DC-DC convertor
- 48V Port

### Limiting Values

Parameter	Conditions		Symbol	Min	Max	Unit		
Drain-source Voltage			$V_{DS}$	-	80	V		
Gate-source Voltage			$V_{GS}$	-20	20			
Continuous Drain Current (Note 1,2)	Steady-State	$T_A=25^\circ\text{C}, V_{GS}=10\text{V}$	$I_D$	-	42.1	A		
		$T_A=100^\circ\text{C}, V_{GS}=10\text{V}$		-	29.8			
Continuous Drain Current (Note 1,3)	Steady-State	$T_C=25^\circ\text{C}, V_{GS}=10\text{V}, \text{Chip limitation}$		-	453			
		$T_C=100^\circ\text{C}, V_{GS}=10\text{V}$		-	320			
Pulsed Drain Current	$T_C=25^\circ\text{C}, t_p \leq 10\mu\text{s}$			$I_{DM}$	-		1812	
Maximum Body-Diode Continuous Current	$T_C=25^\circ\text{C}$			$I_S$			360	
Avalanche Energy (non-repetitive )	$T_J=25^\circ\text{C}, V_G=10\text{V}, R_G=25\Omega, L=1\text{mH}, I_{AS}=56\text{A}$		EAS	-	1568	mJ		
Total Power Dissipation (Note 1,2)	Steady-State	$T_A=25^\circ\text{C}$	$P_D$	-	4	W		
		$T_A=100^\circ\text{C}$		-	2			
Total Power Dissipation (Note 1,3)	Steady-State	$T_C=25^\circ\text{C}$		-	468			
		$T_C=100^\circ\text{C}$		-	234			
Junction and Storage Temperature Range				$T_J, T_{STG}$	-55		175	$^\circ\text{C}$

### Thermal Resistance

Parameter		Symbol	Typ	Max	Units
Thermal Resistance Junction-to-Ambient (Note 2)	Steady-State	$R_{\theta JA}$	-	37	$^\circ\text{C/W}$
Thermal Resistance Junction-to-Case	Steady-State	$R_{\theta JC}$	-	0.32	



# YJTL1D1G08MQ

## ■ Electrical Characteristics

Parameter	Symbol	Conditions	Min	Typ	Max	Units
<b>Static Parameter</b>						
Drain-Source Breakdown Voltage	$BV_{DSS}$	$V_{GS}=0V, I_D=1mA, T_j=25^\circ C$	80	-	-	V
Zero Gate Voltage Drain Current	$I_{DSS}$	$V_{DS}=80V, V_{GS}=0V, T_j=25^\circ C$	-	-	1	$\mu A$
		$V_{DS}=80V, V_{GS}=0V, T_j=125^\circ C$	-	-	100	
Gate-Source Leakage Current	$I_{GSS}$	$V_{GS}=\pm 20V, V_{DS}=0V, T_j=25^\circ C$	-	-	$\pm 100$	nA
Gate Threshold Voltage	$V_{GS(th)}$	$V_{DS}=V_{GS}, I_D=250\mu A, T_j=25^\circ C$	2.2	3	3.8	V
Static Drain-Source On-Resistance	$R_{DS(on)}$	$V_{GS}=10V, I_D=50A, T_j=25^\circ C$	-	0.86	1.13	m $\Omega$
Diode Forward Voltage	$V_{SD}$	$I_S=50A, V_{GS}=0V, T_j=25^\circ C$	-	0.78	1.2	V
Gate Resistance	$R_G$	$f=1MHz, T_j=25^\circ C$	-	3.2	-	$\Omega$
<b>Dynamic Parameters</b>						
Input Capacitance	$C_{iss}$	$V_{DS}=40V, V_{GS}=0V, f=1MHz, T_j=25^\circ C$	-	12790	-	$\mu F$
Output Capacitance	$C_{oss}$		-	3130	-	
Reverse Transfer Capacitance	$C_{rss}$		-	106	-	
<b>Switching Parameters</b>						
Total Gate Charge	$Q_g$	$V_{GS}=10V, V_{DS}=40V, I_D=50A, T_j=25^\circ C$	-	219	-	nC
Gate-Source Charge	$Q_{gs}$		-	55	-	
Gate-Drain Charge	$Q_{gd}$		-	69	-	
Reverse Recovery Charge	$Q_{rr}$	$I_F=50A, di/dt=100A/\mu s, V_{GS}=0V, V_R=40V, T_j=25^\circ C$	-	158	-	nC
Reverse Recovery Time	$t_{rr}$		-	84	-	ns
Turn-on Delay Time	$t_{D(on)}$	$V_{GS}=10V, V_{DS}=40V, I_D=50A, R_{GEN}=3\Omega, T_j=25^\circ C$	-	23.5	-	ns
Turn-on Rise Time	$t_r$		-	152	-	
Turn-off Delay Time	$t_{D(off)}$		-	110	-	
Turn-off Fall Time	$t_f$		-	120	-	

### Note:

1. The entire application environment impacts the thermal resistance values shown, they are not constants and are only valid for the particular conditions noted.
2. The value of  $R_{\theta JA}$  is measured with the device mounted on the 40mm\*40mm\*1.1mm single layer FR-4 PCB board with 1 in<sup>2</sup> pad of 2oz. Copper, in the still air environment with  $T_A=25^\circ C$ . The maximum allowed junction temperature of 175 $^\circ C$ . The value in any given application depends on the user's specific board design.
3. Thermal resistance from junction to soldering point (on the exposed drain pad).



# YJTL1D1G08MQ

## Typical Electrical and Thermal Characteristics Diagrams

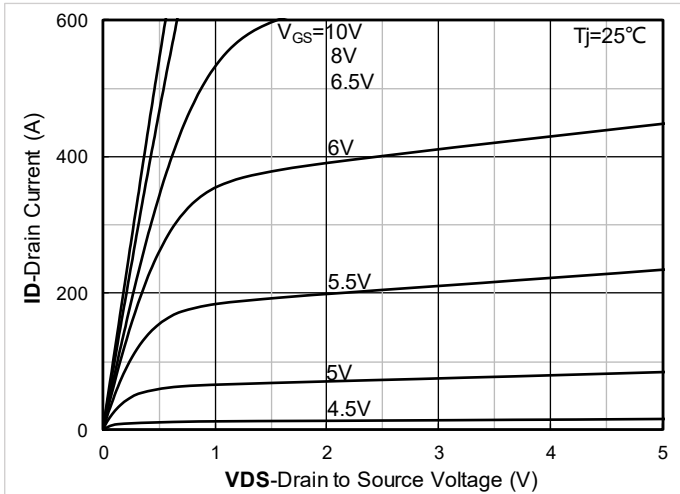

Figure 1. Output Characteristics; typical values

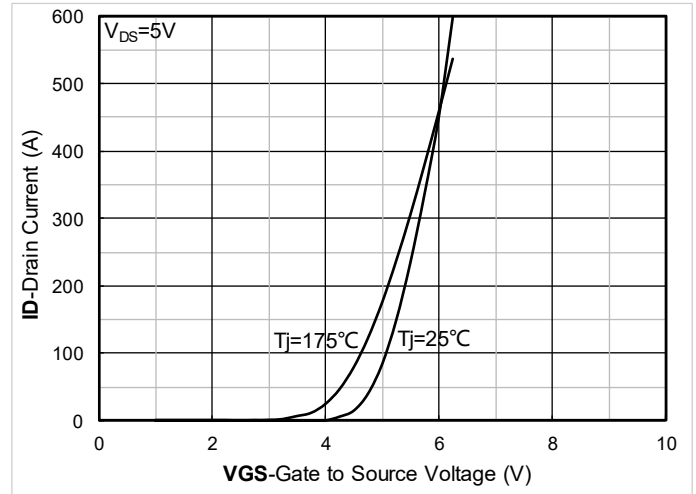

Figure 2. Transfer Characteristics; typical values

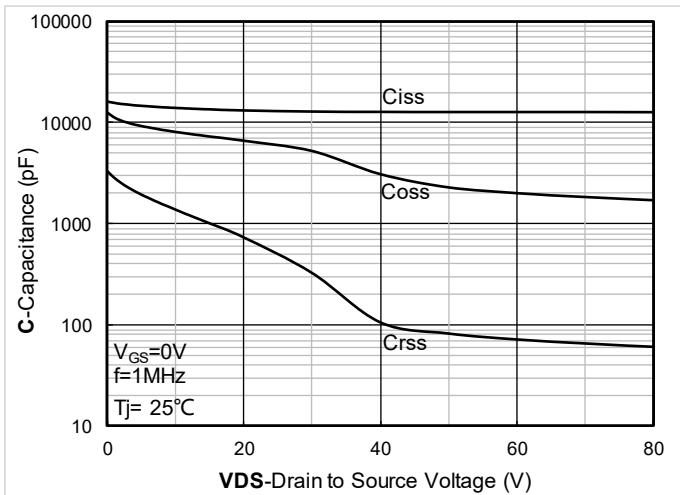

Figure 3. Capacitance Characteristics; typical values

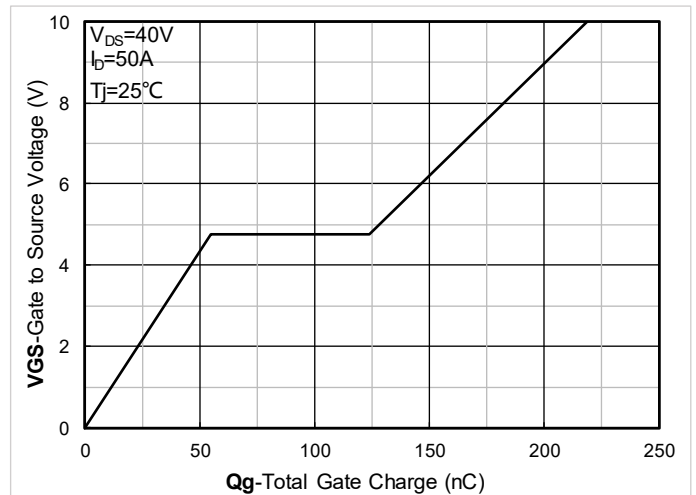

Figure 4. Gate Charge; typical values

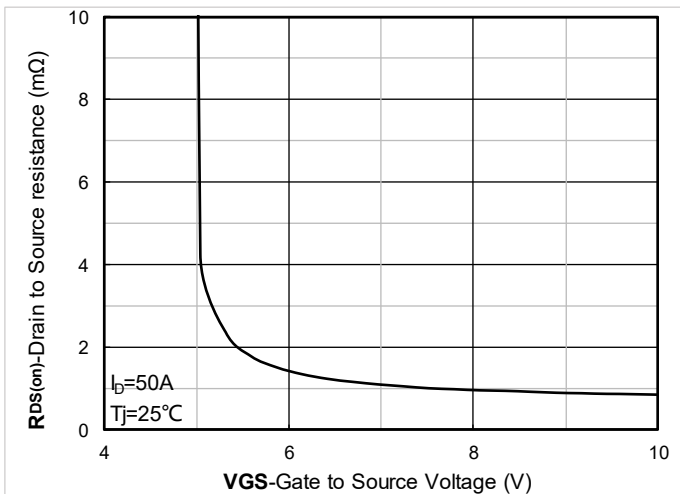

Figure 5. On-Resistance vs. Gate to Source Voltage; typical values

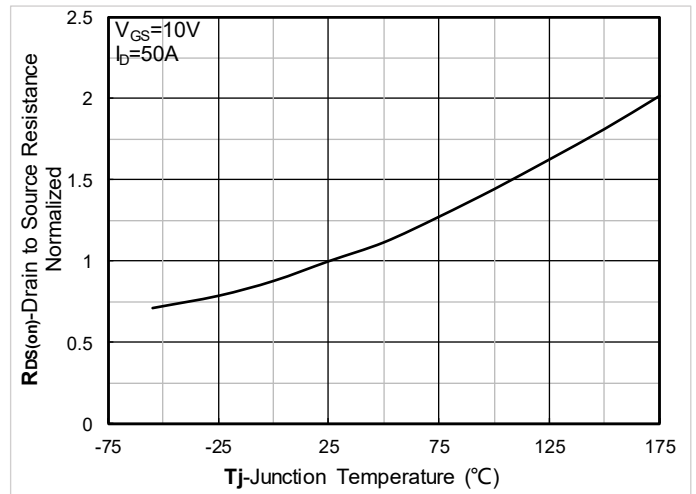

Figure 6. Normalized On-Resistance



# YJTL1D1G08MQ

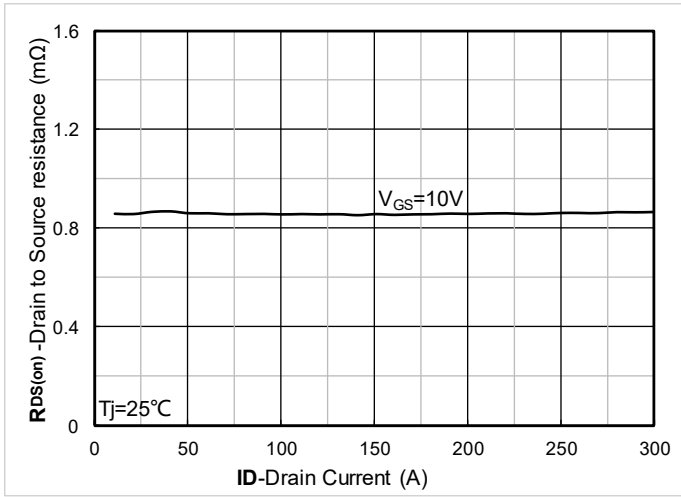

Figure 7. RDS(on) vs. Drain Current; typical values

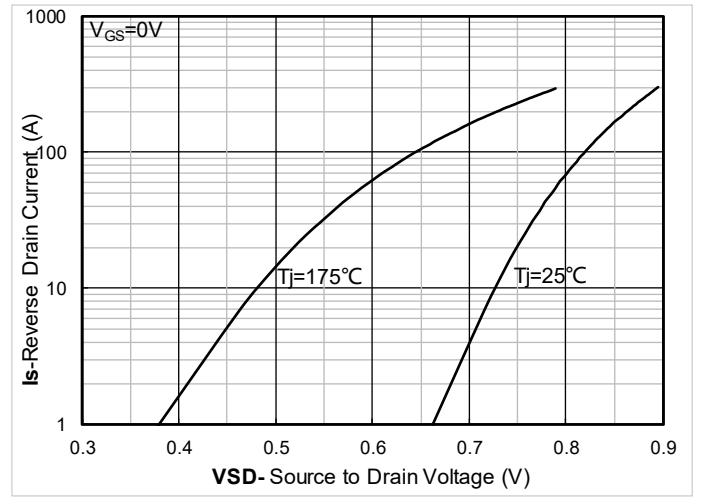

Figure 8. Forward characteristics of reverse diode; typical values

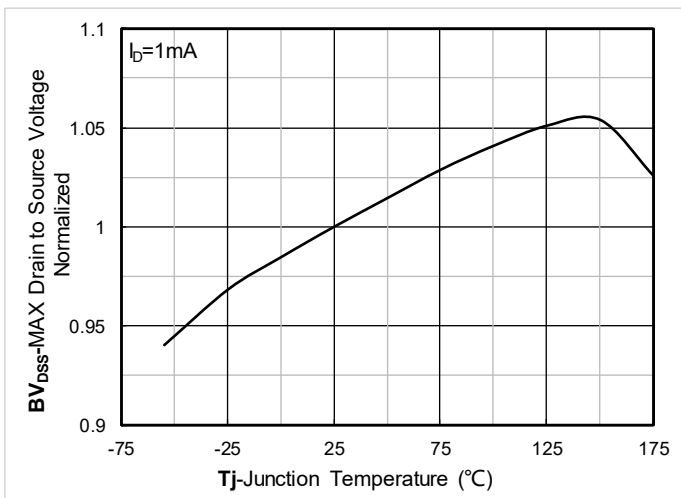

Figure 9. Normalized breakdown voltage

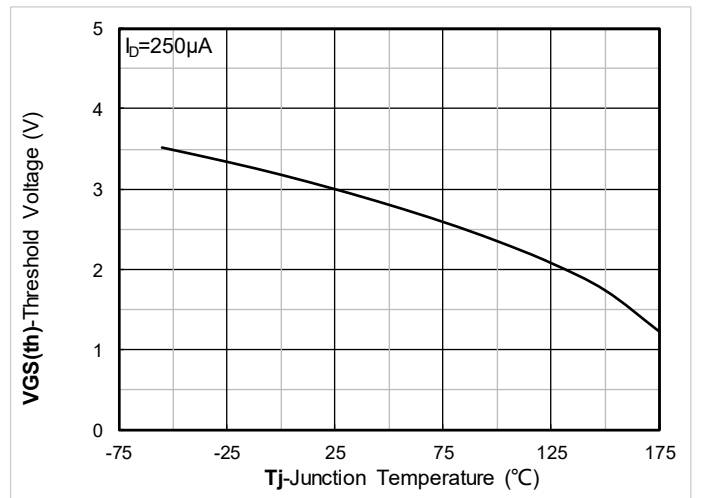

Figure 10. Gate Threshold voltage; typical values

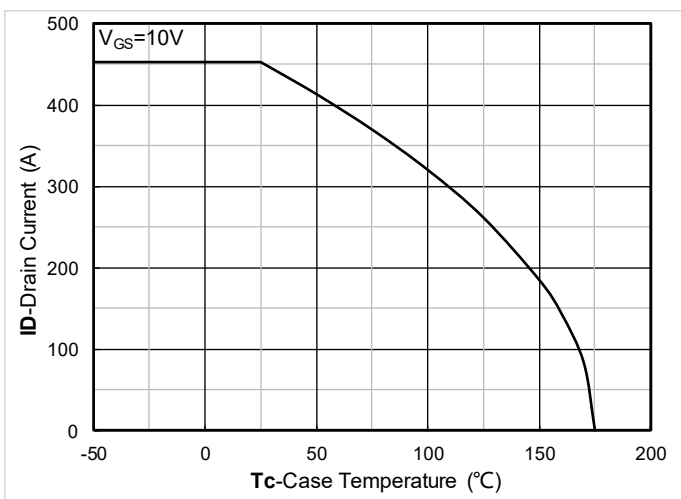

Figure 11. Current dissipation

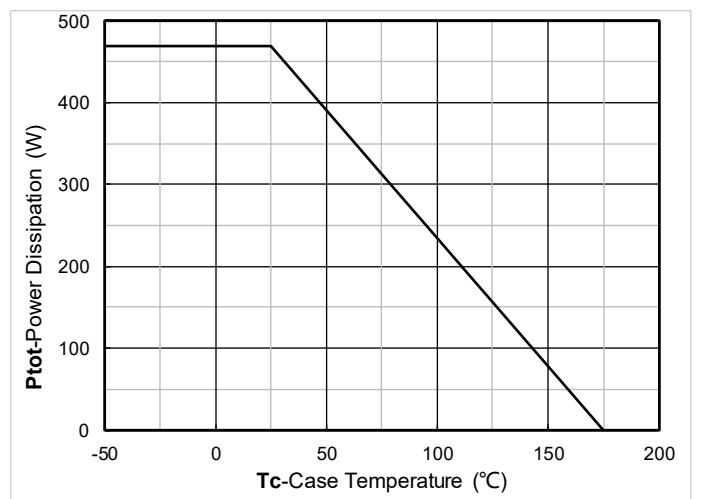

Figure 12. Power dissipation



# YJTL1D1G08MQ

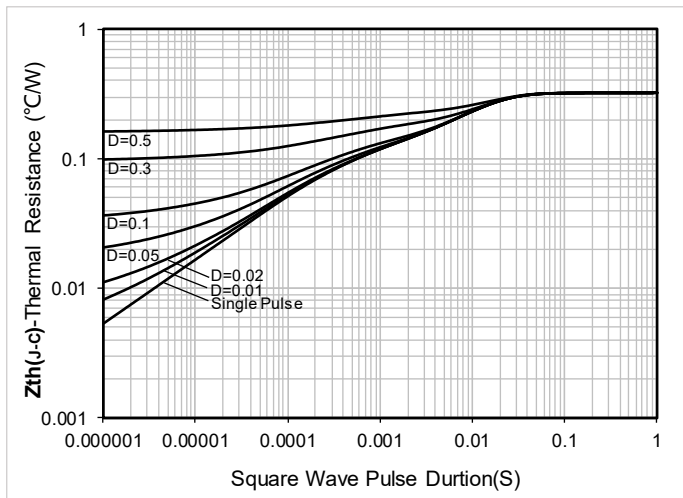

Figure 13. Maximum Transient Thermal Impedance

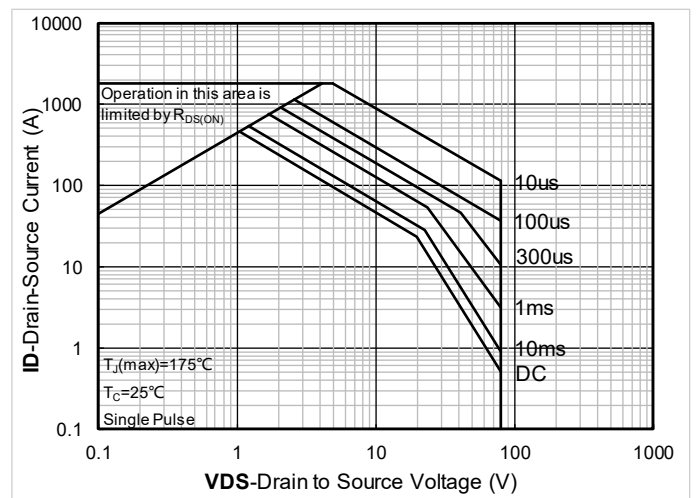

Figure 14. Safe Operation Area

## ■ Test Circuits & Waveforms

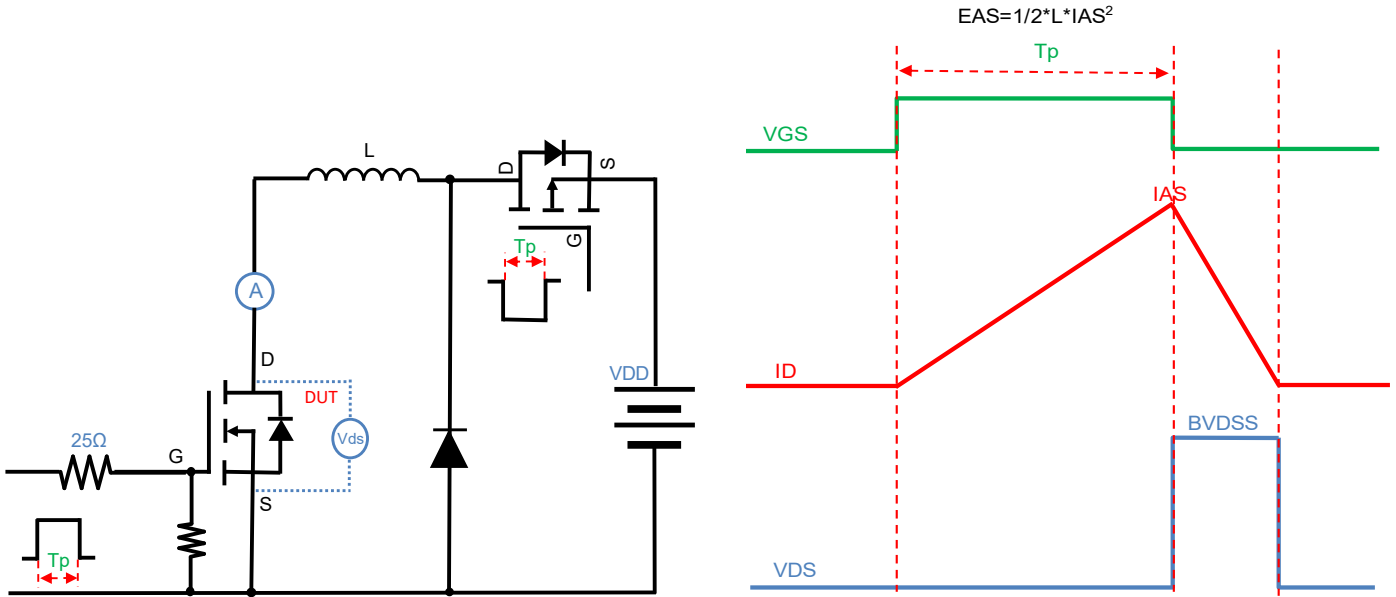

Figure A. Unclamped Inductive Switching (UIS) Test Circuit & Waveform

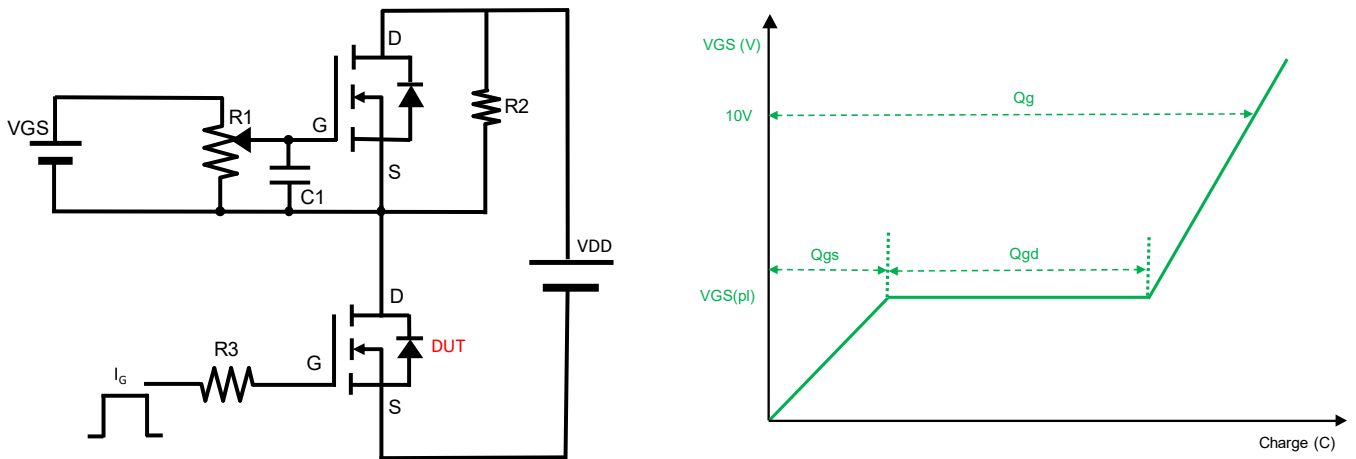

Figure B. Gate Charge Test Circuit & Waveform

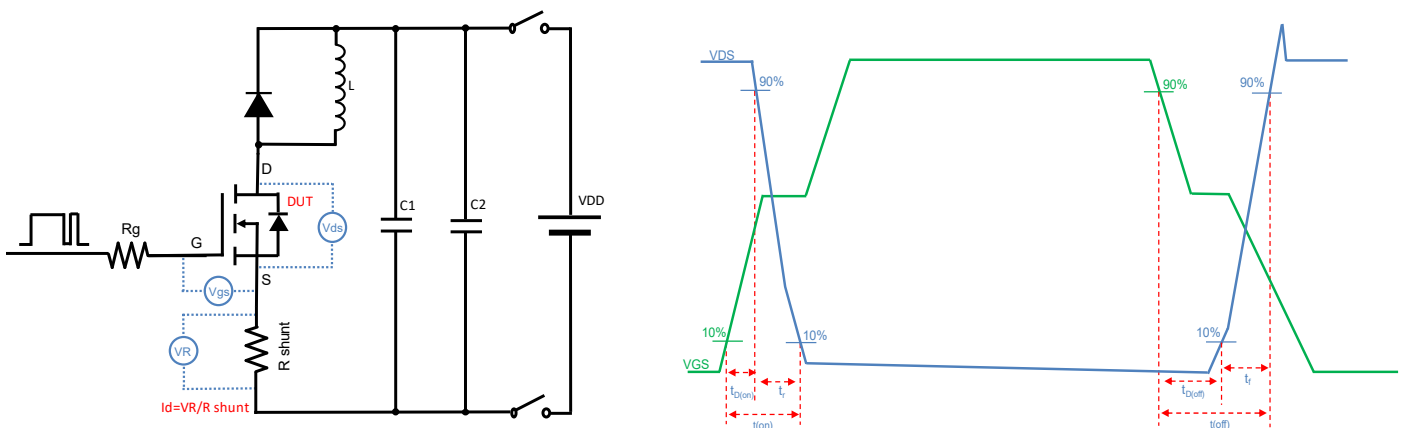

Figure C. Resistive Switching Test Circuit & Waveform





# YJTL1D1G08MQ

## ■ TOLT Package Information

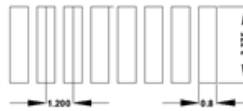
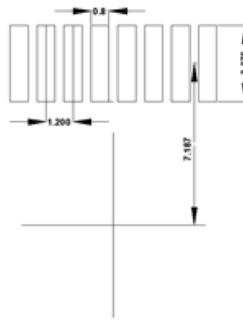
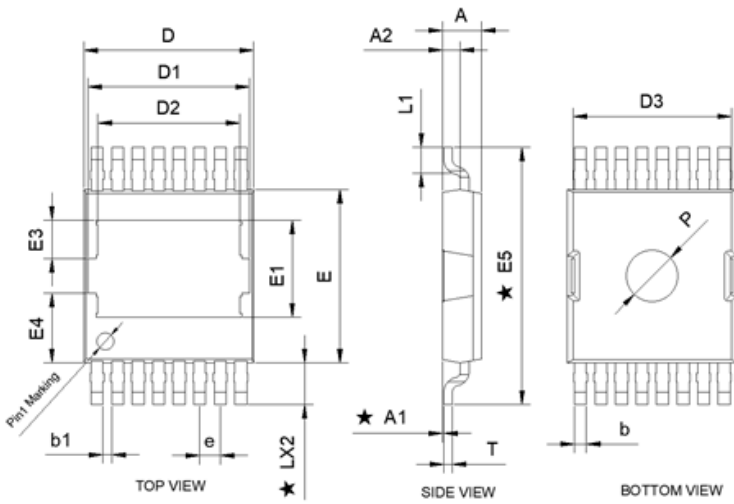

SUGGESTED SOLDER PAD LAYOUT

SYMBOL	MILLMETER		
	MIN	NOR	MAX
A	2.25	2.30	2.35
A1	0.01	0.08	0.16
A2	0.99	1.04	1.09
b	0.60	0.70	0.80
b1	0.40	0.50	0.60
D	9.70	9.90	10.10
D1	9.36	9.46	9.56
D2	8.20	8.30	8.40
D3	9.17	9.27	9.37
e	1.20BSC		
E	10.00	10.10	10.30
E1	5.47	5.67	5.87
E2	1.90	2.00	2.10
E3	2.05	2.25	2.45
E4	3.90	4.05	4.20
E5	14.80	15.00	15.20
L	2.20	2.45	2.70
L1	1.51REF		
T	0.458	0.508	0.558
P	2.80	3.00	3.20

Note:

1. Controlling dimension: in millimeters.
2. General tolerance:  $\pm 0.10\text{mm}$ .
3. The pad layout is for reference purposes only.
4. ★ It is the key size.



# YJTL1D1G08MQ

## ■ Marking Information

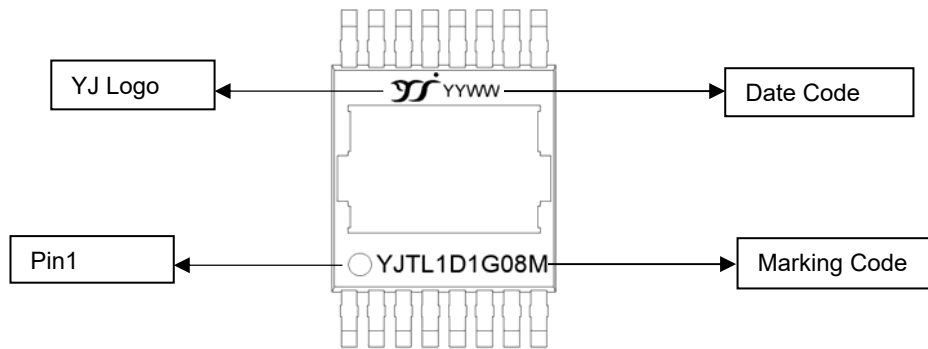

**Note:**

1. All marking is at middle of the product body
2. All marking is in laser printing
3. YJTL1D1G08M is marking code, YYWW is date code, "YY" is year, "WW" is week
4. Body color: Black



## YJTL1D1G08MQ

---

### Disclaimer

The information presented in this document is for reference only. Yangzhou Yangjie Electronic Technology Co., Ltd. reserves the right to make changes without notice for the specification of the products displayed herein to improve reliability, function or design or otherwise.

The product listed herein is designed to be used with automotive electronics, are not designed for use in medical, life-saving, lifesustaining, or military, Yangjie or anyone on its behalf, assumes no responsibility or liability for any damages resulting from such improper use of sale.

This publication supersedes & replaces all information previously supplied. For additional information, please visit our website <http://www.21yangjie.com>, or consult your nearest Yangjie's sales office for further assistance.